

QSFP28 100G SR4 Transceiver

Product Features

- 4x25Gb/s, 850nm, Compliant to the IEEE 802.3bm(100GBASE-SR4)
- Compliant to the QSFP28 MSA SFF-8636
- Built-in digital diagnostic functions
- VCSEL array transmitter and PIN array receiver
- Single +3.3V power supply, and maximum 2.5W operation power
- Operation case temperature of 0~70°C
- Operating Data rate: up to 25.78125G for each lane
- RoHS6 compliance, and Class 1 laser safety
- Transmission distance up to 70m (OM3) and 100m (OM4) optional
- Application: 100G Ethernet

Operating Conditions

Parameter	Unit	Min.	Typical	Max.
Storage Temperature	°C	-10		85
Operating Case Temp for C-temp	°C	0		70
Power Supply Voltage	V	3.135	3.3	3.465
Power Consumption	W			2.5
Bit Rate	Gbps		25.78125	

Electrical Characteristics

Parameter	Unit	Min.	Typical	Max.	Note
Transmitter					
Data Input Swing Differential/TX	mV	200	-	1600	
Date Differential Impedance	Ω	90	100	110	
Receiver					
Data Output Swing Differential/RX	mV	350	-	1000	
Date Differential Impedance	Ω	90	100	110	

Optical Characteristics

All performance is specified at whole working temperature and conditions

Parameter	Unit	Min.	Typical	Max.	Note
Transmitter (4X25G)					
Signaling rate, each lane	Gbps		25.78125		
TX Central Wavelength	nm	840	850	860	
Spectral Width (RMS)	nm			0.6	
Average Launch Power, each lane	dBm	-8.4		2.4	
Optical Modulation Amplitude (OMA)	dBm	-6.4		3.0	
Average Launch power Tx_off	dBm			-30	
Extinction Ratio	dB	2			
Optical Return Loss Tolerance	dB			12	1
Encircled Flux		>86% at 19 um <30% at 4.5 um			
Transmitter eye mask definition {X1, X2, X3, Y1, Y2, Y3} Hit ratio 5×10^{-5} hits per sample		{0.3, 0.38, 0.45, 0.35, 0.41, 0.5}			
Receiver (4X25G)					
Signaling rate, each lane	Gbps		25.78125		
RX Central Wavelength	nm	840	850	860	
Overload Input Optical Power	dBm	2.5			
Average Receive Power per Lane	dBm	-10.3		2.4	
Receive Power (OMA) per Lane	dBm			3	
Receiver Reflectance	dB			-12	
Stressed Receiver Sensitivity (OMA) per Lane	dBm			-5.2	
Stressed Conditions:					
Stressed Eye Closure	dB	4.3			
Stressed Eye J2 Jitter		0.39			
Stressed Eye J4 Jitter		0.53			
OMA of each aggressor lane		3			
Stressed Receiver Eye Mask Definition {X1, X2, X3, Y1, Y2, Y3}		{0.28,0.5,0.5,0.33,0.33,0.4}			
LOS Assert	dBm	-30			
LOS De-Assert	dBm			-12	
LOS Hysteresis	dB	0.5			

Note:

1. Coupled into 50/125 MMF.

Optical Interface

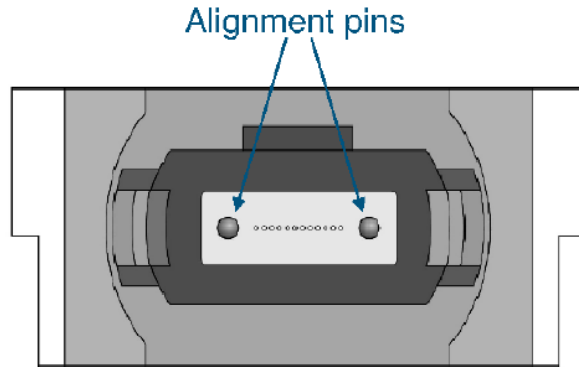

Transmit Channels: 1 2 3 4
 Unused positions: x x x x
 Receive Channels: 4 3 2 1

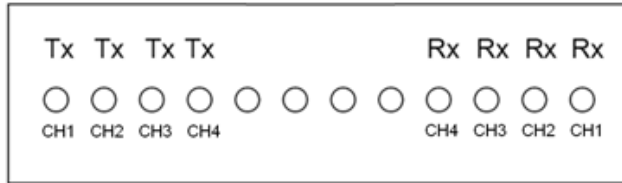

PIN Definition

Pin No.	Symbol	Level / Logic	Description
1	GND		Module Ground
2	Tx2n	CML-I	Transmitter Inverted Data Input
3	Tx2p	CML-I	Transmitter Non-Inverted Data Input
4	GND		Module Ground
5	Tx4n	CML-I	Transmitter Inverted Data Input
6	Tx4p	CML-I	Transmitter Non-Inverted Data Input
7	GND		Module Ground
8	ModSelL	LVTTL-I	Module Select
9	ResetL	LVTTL-I	Module Reset
10	VccRx		+3.3V Power Supply for Receiver
11	SCL	LVTTL-I	2-Wire Serial Interface Clock
12	SDA	LVTTL-I/O	2-Wire Serial Interface Data Line
13	GND		Module Ground
14	Rx3p	CML-O	Receiver Non-Inverted Data Output
15	Rx3n	CML-O	Receiver Inverted Data Output
16	GND		Module Ground
17	Rx1p	CML-O	Receiver Non-Inverted Data Output
18	Rx1n	CML-O	Receiver Inverted Data Output
19	GND		Module Ground
20	GND		Module Ground
21	Rx2n	CML-O	Receiver Inverted Data Output
22	Rx2p	CML-O	Receiver Non-Inverted Data Output
23	GND		Module Ground
24	Rx4n	CML-O	Receiver Inverted Data Output
25	Rx4p	CML-O	Receiver Non-Inverted Data Output
26	GND		Module Ground
27	ModPrsL	LVTTL-O	Module Present
28	IntL	LVTTL-O	Interrupt
29	VccTx		+3.3V Power Supply for Transmitter
30	Vcc1		+3.3V Power Supply
31	LPMMode	LVTTL-I	Low Power Mode
32	GND		Module Ground
33	Tx3p	CML-I	Transmitter Non-Inverted Data Input
34	Tx3n	CML-I	Transmitter Inverted Data Input
35	GND		Module Ground
36	Tx1p	CML-I	Transmitter Non-Inverted Data Input
37	Tx1n	CML-I	Transmitter Inverted Data Input
38	GND		Module Ground

1: GND is the symbol for signal and supply (power) common for the QSFP28 module. All are common within the QSFP28 module and all module voltages are referenced to this potential unless otherwise noted. Connect these directly to the host board signal-common ground plane.

2: Vcc Rx, Vcc1 and Vcc Tx are the receiver and transmitter power supplies and shall be applied concurrently. Vcc Rx, Vcc1 and Vcc Tx may be internally connected within the QSFP28 Module in any combination.

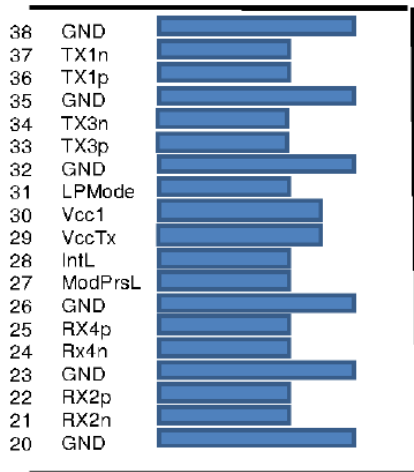
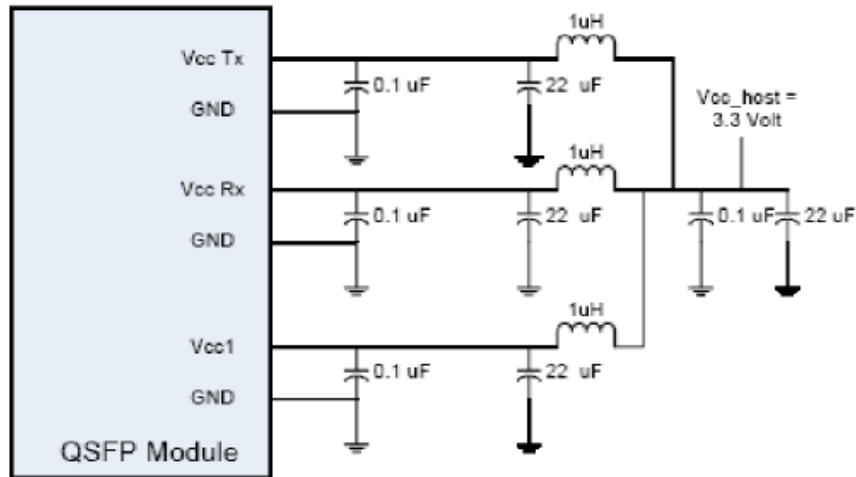

Top Side
Viewed From Top

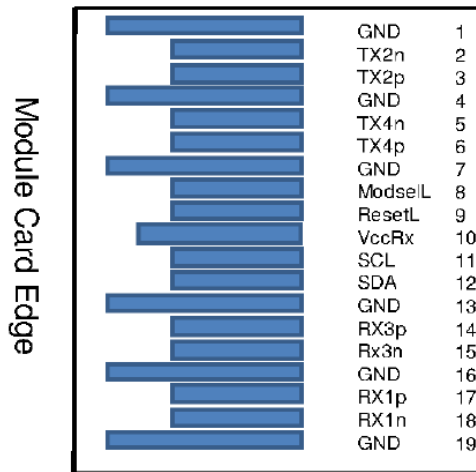

Bottom Side
Viewed From Bottom

Module Card Edge

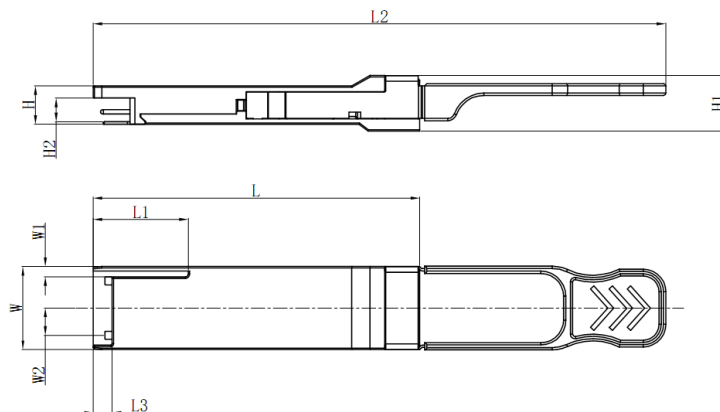
OUTLINES

Unit mm

	L	L1	L2	L3	W	W1	W2	H	H1	H2
Max	72.2	-	128	4.35	18.45	-	6.2	8.6	12.0	5.35
Type	72.0	-	-	4.20	18.35	-	-	8.5	11.8	5.2
Min	68.8	16.5	124	4.05	18.25	2.2	5.8	8.4	11.6	5.05

Ordering Information

Ordering P/Ns	Description
DH88hh-QMCA	4x25G QSFP28 SR4, 850nm, MMF, MPO, Commercial temperature.

Contact Us
International Sales

Email: Sales@broadex-tech.co.uk

Tel: +44-1506-426021

Mobile: +44-7968-854124

China Sales

Tel: +86-573-82585881

Email: Sales@broadex-tech.com

Copyright © 2020 Broadex Technologies. All rights reserved